

NATIONAL AERONAUTICS AND SPACE ADMINISTRATION

**SPACE SHUTTLE
MISSION
STS-51I**

**PRESS KIT
AUGUST 1985**



ASC-1; AUSSAT-1 LEASAT IV-4; LEASAT IV-3 SALVAGE

STS-51 INSIGNIA

S85-25870 -- The STS-51I insignia is based on a strong patriotic theme with the basic colors of red, white and blue suggesting the American flag and a dominant American bald eagle in aggressive flight. The shock wave represents that formed by the orbiter during the entry phase of the flight. Surnames of crewmembers surround the top part of the circular design.

The NASA insignia design for space shuttle flights is reserved for use by the astronauts and for other official use as the NASA Administrator may authorize. Public availability has been approved only in the form of illustrations by the various news media. When and if there is any change in this policy, which we do not anticipate, it will be publicly announced.

PHOTO CREDIT: NASA or National Aeronautics and Space Administration.

CONTACTS

Charles Redmond/Sarah Keegan
Headquarters, Washington, DC
(Phone: 202/453-8536)

David Alter
Johnson Space Center, Houston, TX
(Phone: 713/483-5111)

Jim Ball
Kennedy Space Center, FL
(Phone: 305/867-2468)

Ralph B. Jackson
Dryden Flight Research Facility, Edwards CA
(Phone: 805/258-8381)

CONTENTS

GENERAL RELEASE	5
51I BRIEFING SCHEDULE	8
GENERAL INFORMATION	9
SHUTTLE MISSION 51-I QUICK-LOOK FACTS	10
51-I TRAJECTORY SEQUENCE OF EVENTS	12
SUMMARY OF MANAGEMENT ACTIVITIES	13
STS 51-I PAYLOAD AND VEHICLE WEIGHTS SUMMARY	14
PHYSICAL VAPOR TRANSPORT OF ORGANIC SOLIDS (PVTOS)	15
ASC-1	16
AUSSAT-1	17
LEASAT-4	18
LEASAT SALVAGE MISSION	19
STS 51-I CREW MEMBER DATA	26

51-I SHUTTLE MISSION TO DEPLOY THREE SATELLITES AND REPAIR LEASAT

Mission 51-I will be another bold endeavor in space when astronauts repair and salvage the lifeless Leasat/Syncom IV-F3 satellite on orbit and redeploy it for normal operation.

Launch of the 20th Space Shuttle mission is currently planned for no earlier than Saturday, Aug. 24, 1985. Discovery is scheduled to begin its sixth trip into space with a liftoff at approximately 8:51 a.m. EDT.* The window for that date is open for 21 minutes, extending to 9:12 a.m. EDT.

Highlights of the 8-day mission include the second repair of a satellite in space and deployment of the ASC-1/PAM-D for American Satellite Co., the AUSSAT-1/PAM-D satellite for the Australian government, and the Leasat IV-F4 satellite for the U.S. Navy. The Physical Vapor Transport of Organic Solids (PVTOS) experiment, sponsored by the 3M Corp., will be conducted in Discovery's middeck.

Joe H. Engle will command the 51-I flight. He was commander of the STS-2 flight. Pilot Richard O. Covey will be making his first Shuttle flight. Mission specialist James D. van Hoften, known to his crewmates as "Ox," flew on mission 41-C and helped successfully repair the ailing Solar Maximum Mission satellite. Mission specialists William F. Fisher and John M. Lounge will be making their first flight into space.

Van Hoften and Fisher will be performing the extravehicular activity (EVA) for the repair of the Leasat 3 satellite. In addition, van Hoften will be responsible for the deployment of the Leasat 4 satellite and operation of 3M's PVTOS experiment. Fisher will deploy the ASC-1 satellite and serve as the space mechanic for Leasat 3. Lounge will deploy the AUSSAT-1 satellite, maneuver the remote manipulator arm, and will be the flight engineer during the ascent and reentry portion of the mission.

Discovery will be launched into a circular orbit of 219 statute miles and will have a 28.5-degree inclination to the equator. A series of orbital maneuvering system and reaction control system burns will place the Shuttle in a 278-by-196-statute-mile orbit.

On flight day 1, the ASC-1 satellite will be deployed and the 3M PVTOS experiment will be activated. ASC-1 will be assigned to a 138-degree west longitude operational location and has a 10-year life expectancy. After deployment, the PAM-D will fire and place the spacecraft into a synchronous transfer orbit.

ASC's Star-30 apogee kick motor will be fired at the appropriate time to circularize the orbit at 22,300 statute miles. Built by RCA Astro Electronics, Princeton, NJ, the satellite will be controlled from Atlanta and will provide commercial communications services to all 50 states and Puerto Rico.

American Satellite Co. provides voice, data, facsimile, and video conferencing communications services to more than 450 businesses and government agencies. ASC-1, one of two in the series, will help meet the increased demand for services.

Physical Vapor Transport of Organic Solids (PVTOS) is the second of some 70 experiments the 3M Corp. plans to conduct aboard the Space Shuttle in the next 10 years.

On this mission, solid materials will be vaporized into a gaseous state to form thick crystalline films on selected substrates of sublimable organics.

The first experiment, Diffusive Mixing of Organic Solvents (DMOS), flown in November 1984 dissolved materials which led to a solid crystalline product.

3M researchers will study crystals produced by PVTOS for their optical properties and other characteristics that might ultimately have important applications to 3M's businesses in the areas of electronics, imaging and health care.

AUSSAT-1, a Hughes 376 model, will be deployed on flight day 2. The satellite has 11 12-watt transponders and four 30-watt transponders to provide domestic communications to Australia's 15 million population and to improve air traffic control services. AUSSAT, a corporation wholly owned by the government, was formed in 1982 to provide domestic communications to Australia on a commercial basis.

About 45 minutes after deployment, the first stage rocket will fire and on the fourth apogee, the apogee kick motor will be fired by ground controllers in Sydney, Australia, where mission events will be conducted from that point on. Australian controllers will conduct about 3 weeks of on-orbit testing on their first communications satellite and normal operation is expected by Oct. 1.

On flight day 3, Leasat 4 will be ejected using the Frisbee-style deployment and 51-I pilot Covey will begin a series of phase and height adjust maneuvers for the Leasat F-3 rendezvous.

The ejection sequence is initiated when the four locking pins are retracted. An explosive device at the fifth contact point releases a spring that ejects the satellite in a Frisbee motion.

When Leasat is 500 feet from the Shuttle, the omnidirectional antenna is automatically raised from its stowed position. A series of firings are then required to place the spacecraft into geostationary orbit. Leasat has a life expectancy of 10 years.

The Leasat/Syncom series of satellites are owned and operated by Hughes Communications Services, Inc., a wholly-owned subsidiary of Hughes Aircraft Co., and leased to the Naval Space Command Operations Center in Dahlgren, Va., to provide worldwide communications services to the Naval Electronic Systems command.

Flight day 4 will include more phasing maneuvers to intercept the Leasat 3 spacecraft. Mission specialists van Hoften and Fisher will begin preparing the EVA equipment including checkout of the extravehicular mobility units (EMU) and manned maneuvering units on the fifth flight day. The PVTOS experiment is scheduled to be completed on that day.

Depressurization of Discovery's crew cabin from 14.7 psi to 10.2 psi is scheduled to begin on flight day 6 in preparation for flight day 7's EVA, as well as further checkout of the equipment to be used for the 5 1/2-hour satellite repair operation.

During the salvage operation, modifications will be made to the satellite to permit ground command of the activation sequence. Modifications made during the rendezvous will bypass all hardware likely to have been the cause of the failure.

Leasat 3 was successfully deployed April 13 during the 51-D mission but the spacecraft's automated sequencer failed to initiate antenna deployment, spin-up and ignition of the perigee kick motor. That mission was extended two days and an unplanned spacewalk was performed for an unsuccessful attempt to activate the satellite. The satellite is currently drifting in low-Earth orbit without command and telemetry capability.

Discovery will approach the slow spinning satellite to within a distance of 35 feet.

Once secured to the end of the Shuttle's 50-foot robot arm, van Hoften will pluck Leasat out of space with a special device and present it to Fisher. Fisher will be secured at a work station in Discovery's payload bay and will move the satellite's separation lever to the safe position.

He then will grapple the spacecraft with a special handling bar and continue holding it until van Hoften is in position to take over control with the robot arm.

Fisher will perform the mechanical repair work to various parts of the spacecraft including installation of the ground control electronics box, a unit that will deploy the omni antenna, and he will verify that power is on the spacecraft.

After the salvage is complete, Fisher will stabilize Leasat and van Hoften will install the spin-up bar on the spacecraft. Discovery and the repaired Leasat 3 will be maneuvered to the deploy attitude. Van Hoften will begin the deploy by lifting the seemingly weightless spacecraft with a spin-up bar to start a rotation of about 8/10 rpm. Commander Engle will be carefully station keeping the Discovery with the Leasat and van Hoften will continue applying impulses until the spacecraft reaches 2 rpm. At that point, van Hoften will separate the spin-up bar from the spacecraft and it will be turned over to Hughes for normal operation.

On flight day 8, the crew will stow cabin equipment and perform normal flight control system and hot fire checkout work.

Discovery is scheduled to land at Edwards Air Force Base, Calif., at 9:58 a.m. EDT, Sept. 1, on orbit 127. Touchdown will come at about 8 days, 1 hour and 7 minutes mission elapsed time.

NOTE: At press time, the planned 51-I mission is baselined for 8 days, with a launch time of 8:51 a.m. EDT, Aug. 24; flight day 6 open; Leasat salvage operations on flight day 7; and landing on Sept. 1 (flight day 9). A proposed optional Crew Activity Plan is now under consideration. This new plan would be baselined as a 7-day mission, launched at 8:39 a.m., Aug. 24, with salvage operations on flight day 6, and landing on Aug. 31 (flight day 8). If additional salvage operation time is needed, flight day 7 would be used for this effort, with a landing on Sept. 1 (flight day 9). A decision regarding these changes will be made realtime.

(END OF GENERAL RELEASE; BACKGROUND INFORMATION FOLLOWS.)

51-I BRIEFING SCHEDULE

Time (EDT)	Briefing	Origin
T-1 Day		
9:00 a.m.	PVTOS	KSC
9:30 a.m.	ASC-1	KSC
10:00 a.m.	AUSSAT-1	KSC
10:30 a.m.	Leasat 4 Deployment	KSC
11:00 a.m.	Leasat 3 salvage	TBD
2:00 p.m.	Prelaunch Briefing	KSC
T-Day		
10:00 a.m.	Post-launch Press Conference	KSC
Launch Through End-of-Mission		
Times announced on NASA Select	Flight Director Change-of-Shift Briefings	JSC
Landing Day		
11:00 a.m.	Post-landing Briefing	DFRF

GENERAL INFORMATION

NASA Select Television Transmission

The schedule for television transmissions from the orbiter and for the change-of-shift briefings from Johnson Space Center, Houston, will be available during the mission at Kennedy Space Center, Fla.; Marshall Space Flight Center, Huntsville, Ala.; Johnson Space Center; and NASA Headquarters, Washington, D.C. The television schedule will be updated on a daily basis to reflect changes dictated by mission operations.

NASA has leased from RCA Satcom F-2R, Transponder 13 (half transponder) to carry NASA Select television from launch through landing. Satcom F-2R is located at 72 degrees west longitude. Transponder 13 transmits on a frequency of 3954.5 MHz.

To support commercial/educational users, NASA leases a full transponder during peak hours of Shuttle flights via Satcom F-1R, Transponder 18. Satcom F-1R (C band) is located at 139 degrees west longitude. Transponder 18 transmits on a frequency of 4060.0 MHz, horizontal polarization. A schedule of operating hours will be available separately.

Special Note to Broadcasters

Beginning Aug. 19 and continuing throughout the mission, approximately 7 minutes of audio interview material with the crew of 51-I will be available to broadcasters by calling 202/269-6572.

Status Reports

Status reports on countdown progress, mission progress, on-orbit activities and landing operations will be produced by the appropriate NASA news center.

Briefings

Flight control personnel will be on 8-hour shifts. Change-of-shift briefings by the off-going flight director will occur at approximately 8-hour intervals.

Transcripts

Transcripts of the change-of-shift briefings will be available at the Shuttle news centers.

SHUTTLE MISSION 51-I -- QUICK LOOK FACTS

CREW: Joe H. Engle, Commander
Richard O. Covey, Pilot
James D. A. van Hoften, Mission Specialist (MS-1)
John M. Lounge, Mission Specialist (MS-2)
William P. Fisher, Mission Specialist (MS-3)

Orbiter: Discovery (OV-103)

Launch Site: Kennedy Space Center, Fla., Pad 397A

Launch Dates/Times: Aug. 24 8:51 a.m. to 9:12 (EDT) -- 21 min.
Aug. 25 8:02 a.m. to 8:12 (EDT) -- 10 min.
8:54 a.m. to 8:55 (EDT) -- 1 min.
Aug. 26 8:05 a.m. to 8:20 (EDT) -- 15 min.
Aug. 27 7:17 a.m. to 7:43 (EDT) -- 26 min.

Orbital Inclination: 28.5 degrees

Altitude: 190 by 190 n. mi. (direct insertion)
242 by 170 n. mi. (for Leasat/Syncom repair)

Mission Duration: 8 days, 1 hour, 7 minutes
Deorbit burn orbit 126; land on 127

Landing Date/Time: Sept. 1, 1985; 9:30 a.m. EDT

Primary Landing Site Edwards Air Force Base, Calif., Runway 17

Weather alternate: Kennedy Space Center, Runway 15

Abort: Transatlantic Landing (TAL) -- Dakar, Senegal
Abort Once Around (AOA) -- Edwards Air Force Base

Contingency -- KSC; Edwards; Northrup Strip; Hickam AFB/Honolulu International
(Hawaii); Andersen AFB, Guam; Dakar, Senegal

Cargo and Payloads: ASC-1 (PAM-D) American Satellite Co.
AUSSAT-1 (PAM-D) Australian National Satellite Communications System
Leasat (Syncom) IV-4 Hughes Communications Services, Inc.

Extravehicular: Leasat (Syncom) IV-3 Salvage

Experiments: Physical Vapor Transportation of Organic Solids (PVTOS), 3M Corp.

Highlights: Launch three satellites
Salvage of Leasat (Syncom IV-3)

**National STS Program
STS 51-L Cargo Configuration**

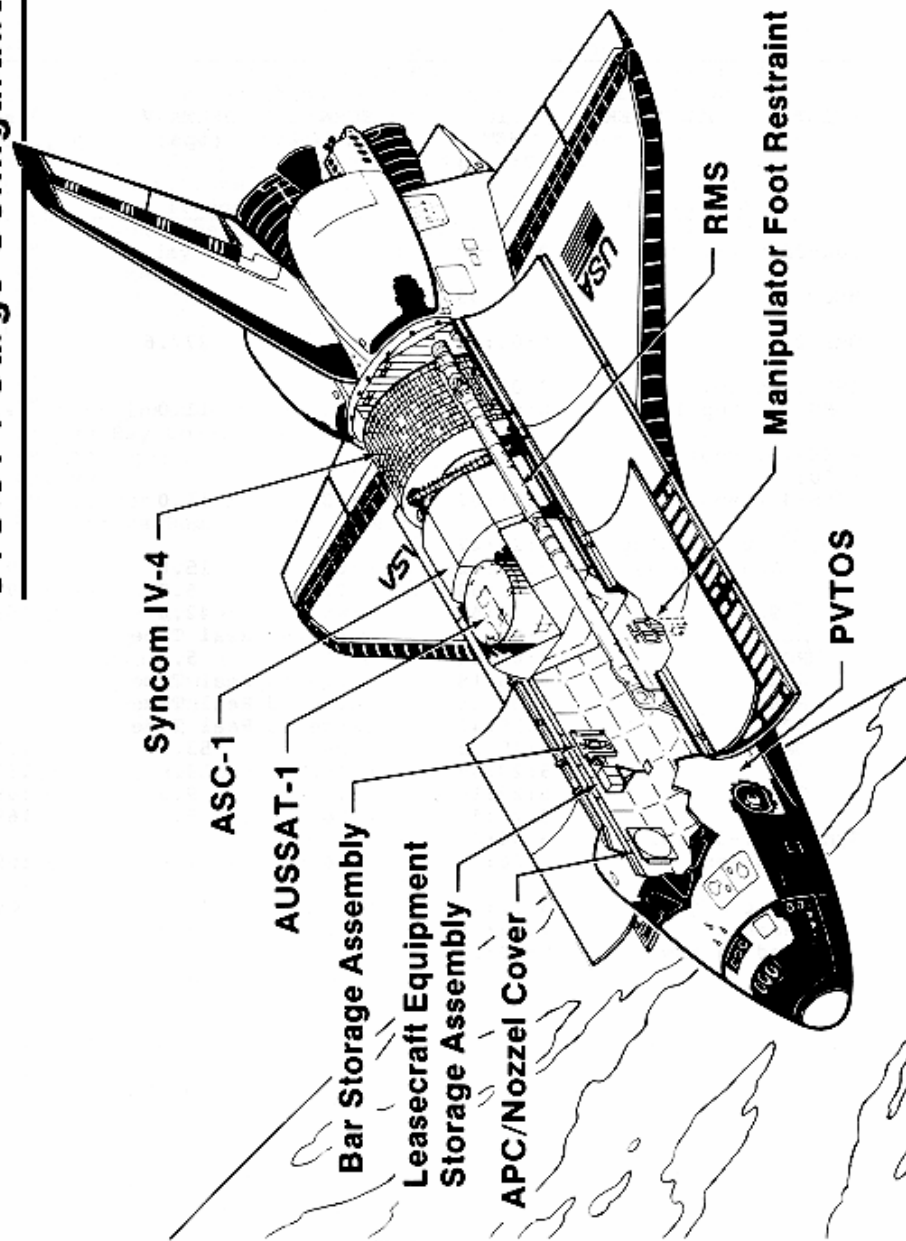

51-I TRAJECTORY SEQUENCE OF EVENTS

Event/maneuver	Tig MET (D:H:M)	Burn Duration (Min-Sec)	Delta v (fps)	Post- Burn Apogee/Perigee (n. mi.)
Launch	0:00:00			
MECO	0:00:09			
OMS-2	0:00:40	2:58	277.6	190 x 190
ASC-1 Deploy	0:09:37			
OMS-3 (Sep 1)	0:09:52	0:13	11.0	190 x 190
AUSSAT-1 Deploy	1:00:52			
OMS-4 (Sep 2)	1:01:07	0:13	11.0	190 x 202
Syncom IV-4 Deploy	1:23:47			
OMS-5 (Sep 3)	2:00:02	0:09	15.0	190 x 210
OMS	2:05:58	0:07	5.9	190 x 213
OMS	2:06:44	0:48	42.6	168 x 211
RCS	3:06:24	Targeted Real Time		
RCS	4:03:53	0:11	5.4	168 x 211
RCS	4:05:18	Targeted Real Time		
RCS	5:05:44	Targeted Real Time		
RCS	5:18:42	Targeted Real Time		
OMS	5:19:28	0:29	53.0	170 x 240
OMS	5:20:46	0:14	13.0	167 x 235
OMS	5:22:18	0:11	9.5	169 x 239
OMS	5:23:40	0:06	5.1	169 x 240
Syncom IV-3 Deploy	6:06:00			
RCS Sep	6:06:12	0:04	2.0	169 x 239
Orbit Adjust	6:21:40	0:47	42.0	169 x 214
Deorbit	7:23:38	3:30	377.0	
Landing EDW	8:00:38			

SUMMARY OF MAJOR ACTIVITIES

NOTE: At press time, the planned 51-I mission is base-lined for 8 days, with a launch time of 8:51 a.m. EDT, Aug. 24; flight day 6, open; Leasat salvage operations on flight day 7; and landing on Sept. 1 (flight day 9). A proposed optional Crew Activity Plan is now under consideration. This new plan would be baselined as a 7-day mission, launched at 8:38 a.m., Aug. 24, with salvage operations on flight day 6, and landing on Aug. 31 (flight day 8). If additional salvage operation time is needed, flight day 7 would be used for this effort, with a landing on Sept. 1 (flight day 9). A decision regarding these changes will be made real-time.

Flight Day 1

Ascent
OMS-2 (direct insertion)
Open Payload Bay Doors
RMS Checkout

ASC-1 Deploy
OMS Sep Maneuver
PVTOS Operations Begin -- Run 1 & 2

Flight Day 2

AUSSAT-1 Deploy
OMS Sep Maneuver
Waste & Supply water Dump
Radiator Performance
PVTOS Runs 3 & 4

Flight Day 3

Syncom IV-4 Deploy
OMS Sep Maneuver

Waste & Supply Water Dump
Rendezvous Phasing
PVTOS Runs 5 & 6

Flight Day 4

Waste & Supply Water Dump
Rendezvous Phasing
PVTOS Runs 7 & 8

Flight Day 5

Waste & Supply Water Dump
EVA Equipment Preparation
EMU Checkout
Rendezvous Phasing (Plane Change and Phase Adjust)
PVTOS Complete (Run 9)

Flight Day 6

Waste & Supply Water Dump
EVA Prep (10.2 psi Cabin)
On-orbit TACAN Nav.
Rendezvous Phasing

Flight Day 7

Rendezvous
EVA (Leasat salvage operations)

Flight Day 8

Orbit Adjustment & Return to 14.7 psi cabin pressure
FCS C/O
Crew Press Conference
Cabin Stowage

Flight Day 9

Deorbit Preparations
Deorbit
Landing

STS 51-I PAYLOAD AND VEHICLE WEIGHTS SUMMARY

	<u>Pounds</u>
Total Payload Bay and Middeck Summary	38,660
Orbiter Plus Cargo at Liftoff	337,661
Total Vehicle at Liftoff	4,518,803
Landing Weight	198,516

PHYSICAL VAPOR TRANSPORT OF ORGANIC SOLIDS

Physical Vapor Transport of Organic Solids (PVTOS) is 3M's second microgravity-based scientific experiment to fly aboard the Shuttle. The first was the Diffusive Mixing of Organic Solutions (DMOS), which flew on mission 51-A in November 1984.

PVTOS consists of nine independent experimental cells housed in an Experimental Apparatus Container which will be mounted on the aft bulkhead in the middeck area. The cells are arranged on a circular baseplate which fits into the NASA-supplied container. The container is backfilled with nitrogen to provide a safe, inert atmosphere for the experiment.

The nine PVTOS experimental cells are about 12 inches long and 3 inches in diameter. Each cell houses a vacuum-insulated, glass and stainless steel ampoule which contains an organic solid at one end and a temperature-controlled substrate at the other end. The solid is vaporized by being heated and migrates through a buffer gas to the substrate which consists of a special metal film previously deposited onto a laser-cut, polished silicon wafer. Vapors condense on the temperature-controlled substrate at the cooler end of the ampoule to form an organic thin film.

The experiment is controlled by 3M's Generic Electronic Module (GEM), a computer containing a microprocessor with bubble memory and providing all the control electronic functions for PVTOS. It serves as an interface between the orbiter and the container and between the crew and the container.

Crew interface is through the handheld keyboard and display terminal. Using this terminal, the crew can select and activate the experiment cells, monitor cell temperatures and power levels and perform diagnostic tests.

The nine cells will be activated two at a time during the flight. The ampoules are designed to operate at up to 400 degrees Centigrade but vacuum insulation around each limits the surface temperature of the cell from 55 to 60 degrees C. Maximum duration of each cell heating is about four hours. Precise temperatures and durations depend upon the organic materials used.

The container with nine PVTOS cells and the GEM computer weighs a total of 165 pounds. The experiment is powered by a 28-volt, direct-current connection to the orbiter. GEM draws 70 watts of power throughout the flight. The container draws 50 to 60 watts for the 30-minute heat-up phase for each cell and 20 watts during the duration of each experiment.

ASC-1

The American Satellite Co. provides voice, data, facsimile and videoconferencing communication services to U.S. businesses and government agencies. ASC-1 is the first wholly-owned commercial communications satellite in a system consisting of two operational spacecraft and one ground spare.

ASC's satellites will operate in both the 6/4 GHz (C-band) and 14/12 GHz (Ku-band) frequencies. The two hybrid satellites, with life expectancies of 10 years, have been assigned orbital locations at 81 degrees and 128 degrees W. longitude. There are both 36 and 72 MHz bandwidth transponders onboard the spacecraft. The total radio frequency power is approximately 300 watts. The 36 MHz C-band transponders use 8.5-watt solid state power amplifiers. These solid state amplifiers provide improved linearity characteristics which permit more carriers per transponder due to a marked reduction in intermodulation noise power.

A unique feature of ASC's satellites is their encrypted command links, a security feature which guards against unauthorized access to the satellite command system. ASC-1 and -2 will be the first commercial spacecraft to have their command links protected by encryption.

The cube-shaped ASC-1 measures 4.3 by 5.3 by 10.5 ft. in the Shuttle cargo bay. With the solar panels deployed on orbit, the length increases to 46.5 ft. tip to tip. Weight of the satellite as it arrives on station is 1,482 lb.

The ASC spacecraft are built by RCA Astro Electronics, Princeton, NJ. The spacecraft tracking, telemetry and control complex for the system is located in Atlanta. American Satellite is also relocating its Network Operations Control Center (NOOC) from its original site in Vernon Valley, NJ, to the Atlanta complex to consolidate satellite and network control functions in a single integrated facility.

AUSSAT-1

AUSSAT, the Australian national satellite communications system, will provide a wide range of domestic services to the entire continent and its offshore islands. This includes direct television broadcast to homesteads and remote communities, high quality television relays between major cities, digital data transmission for both telecommunications and business use, voice applications for urban and remote areas, centralized air traffic control services and maritime radio coverage. AUSSAT-1 is the first in a system of three to be operated by Australia's national satellite company, AUSSAT Proprietary Ltd.

AUSSAT-1 uses two telescoping cylindrical solar panels and a folding antenna for compactness during launch. After the satellite nears its orbital position, the antenna erects and the outer solar panel deploys, exposing the inner solar array.

AUSSAT's antenna system will provide seven transmit beams and three receive beams.

Five transmit beams serve the Homestead and Community Broadcasting Satellite Service (HACBSS): four contiguously placed over the western, central, northeast and southeast regions of the Australian continent and one over Papua, New Guinea. The other two are national beams which provide continental coverage for Fixed Satellite Service.

The AUSSAT satellite will carry 15 channels, each 45 MHz wide. Four will use high power, 30-watt traveling wave tube amplifiers (TWTAs) to provide radio and television services to Australia's remote areas. The remaining 11 channels will operate with 12-watt TWTAs. It will be possible to connect the communications channels individually to the transmit beams by ground command. This arrangement will provide traffic flexibility for the system.

The satellite's diameter is nearly 7.2 feet. Stowed for launch its height is 9.2 ft. In orbit, with antennas deployed and aft solar panel extended, the height will increase to 21.6 m. Its initial on-station weight will be about 1,322 pounds.

The AUSSAT satellites, with a mission life of seven years, will operate at the 14/12 GHz Ku band. Two spacecraft will be located above the equator just north of Papua, New Guinea, at 156 degrees east and 164 degrees east longitude. The third satellite will be located at 160 degrees east longitude.

The master control station for the AUSSAT system will be in Sydney and backup control equipment will be installed in Perth. Monitoring equipment will be installed at Earth stations in Sydney, Perth, Brisbane and Adelaide.

Hughes Space and Communications Group built the three satellites and two telemetry, tracking, command and monitoring stations.

LEASAT 4

Leasat 4, also known as Syncom IV-4, is the fourth satellite in the Leasat system, which will be leased by the Department of Defense to replace the older FleetSatcom spacecraft for worldwide UHF communications between ships, planes and fixed facilities. A Hughes HS 381 design, the Leasat spacecraft is designed expressly for launch from the Space Shuttle and uses the unique Frisbee, or rollout, method of deployment.

The first two spacecraft were deployed during the 41-D and 51-A Shuttle missions. Leasat 3 was deployed successfully during mission 51-D but failed to activate itself. The satellite is currently drifting in low Earth orbit without command and telemetry capability and a salvage operation is scheduled for flight day 7 of mission 51-I.

Interface between the spacecraft and the payload bay is accomplished with a cradle structure. The cradle permits the spacecraft to be installed, lying on its side, with its retracted antennas pointing toward the nose of the orbiter and its propulsion system pointing toward the back. Mounting the antennas on deployable structures allows them to be stowed for launch. Five trunnions (four longeron and one keel) are used to attach the cradle to the Shuttle. Five similarly-located internal attach points are used to attach the spacecraft to the cradle.

Another unique feature of the Leasat series of satellites is no requirement for a separately-purchased upper stage, as have all the other communications satellites launched to date from the Shuttle.

The Leasat satellites contain their own unique upper stage to transfer them from the Shuttle deploy orbit of about 182 mi. to a circular orbit 22,300 mi. over the equator.

Each satellite is 20 ft. long with UHF and omnidirectional antennas deployed. Total payload weight in the Shuttle is 17,000 lb. The satellite's weight on station at the beginning of its planned 7-year life will be nearly 3,060 lb. Hughes' Space and Communications Group builds the satellites.

Ejection of the spacecraft from the Shuttle is initiated when locking pins at the four contact points are retracted. An explosive device then releases a spring that ejects the spacecraft in a "Frisbee" motion. This gives the satellite its separation velocity and gyroscopic stability during the 45-minute coast period between deployment and ignition of the perigee kick motor. The satellite separates from the Shuttle at a velocity of about 1.5 feet per second and a spin rate of about 2 rpm.

A series of maneuvers, performed over a period of several days, will be required to place Leasat into its synchronous orbit over the equator. The process starts 45 minutes after deployment from Discovery with the ignition of the solid propellant perigee motor, identical to that used as the third stage of the Minuteman missile, which will raise the high point of the satellite's orbit to about 9,600 mi.

Two liquid fuel engines that burn hypergolic propellants, monodimethyl hydrazine and nitrogen tetroxide, are used to augment the velocity on successive perigee transits, to circularize the orbit and to align the flight path with the equator.

The first of three such maneuvers raises the apogee to 12,300 mi., the second raises the apogee to 16,100 mi. and the third to geosynchronous orbital altitude. At this point the satellite is in a transfer orbit with a 182-mi. perigee and a 22,300-mi. apogee. The final maneuver, again performed by the liquid propellant engines, circularizes the orbit at the apogee altitude.

Hughes Communications Services, Inc., will operate the worldwide Leasat satellite communications system under a contract with the Department of Defense, with the U.S. Navy acting as the executive agent. The system will include five Leasat satellites, one of which will be a ground spare, and the associated ground facilities. Users will include mobile air, surface, subsurface and fixed Earth stations of the Navy, Marine Corps, Air Force and Army. The satellites will be positioned for coverage of the continental United States and the Atlantic, Pacific and Indian oceans. Leasat 1 and 2 occupy geostationary positions at 105 degrees West and 15 degrees West respectively. Leasat 3 will be positioned at 77 degrees East and Leasat 4 at 178 degrees East.

LEASAT SALVAGE MISSION

STATION KEEP AT 35 FEET

- EV1 ON MFR
- EV2 ON PFR AT LESA

EV1 INSTALL CAPTURE MR AND STABILIZE (A)

RMS AND EV1 PRESENT PIVOT TRUNNIONS TO
EV2 STOW SEPARATION LEVER AND INSTALL (B)

EV1 INSTALL GRAPPLE BAR AND EGRESS MFR
RMS GRAPPLE (C)

EV2

- AT KEEL INSTALL SHORTING PLUGS (D)
- AT NOZZLE INSTALL S&A PINS (E)
- AT 135° REMOVE ACCESS COVER
- AT 90° REMOVE TEST ACCESS COVER (F)
- MATE T CONNECTORS
- INSTALL REPLACEMENT
- AT 135° ROUTE CABLE FROM 90°
- MATE I CONNECTOR
- MOUNT SBU
- AT TOP OF SYNCOM REMOVE DESPUN TEST (G)
- MATE RPU
- ENABLE RDU RELAYS
- DEPLOY OMNI
- CAP CONNECTORS
- INSTALL NEW COVER
- REMOVE S&A PINS
- AT NOZZLE REPLACE NOZZLE COVER

EV2 STABILIZE SYNCOM WITH HANDLING MR

RMS RELEASE. EV1 TO MER

EV1 INSTALL SPINUP BAR (H)

EV2 START SBU TIMERS (I)

MANEUVER SYNCOM AND ORBITER TO DEPLOY

SPIN UP OPERATIONS (I)

EV1 = James "Ox" van Hoften

EV2 = William "Fish" Fisher

MFR = Manipulator Foot Restraint

RMS = Remote Manipulator System (robot arm)

SBU = Spun Bypass Unit

RPU = Remote Power Unit

RDU = Remote Decoder Unit

EV1 = James "Ox" van Hoften
EV2 = William "Fish" Fisher
MFR = Manipulator Foot Restraint
RMS = Remote Manipulator System (robot arm)
SBU = Spun Bypass Unit
RPU = Remote Power Unit
RDU = Remote Decoder Unit

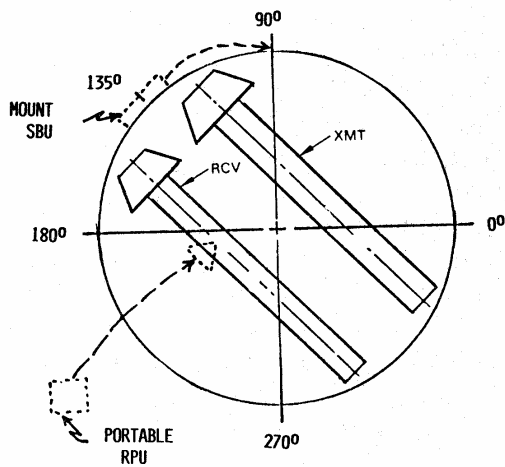
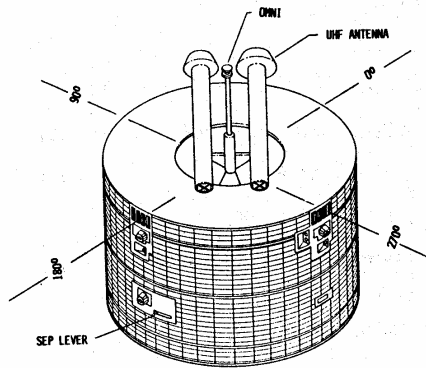

LOCATION	FUNCTION
90°	BATTERY POWER SPUN RDU RELAYS ARM S&A PYRO BUS STATUS PES START INHIBITS
135°	SBU CMDS FROM INSIDE S/C PKM FIRE SQUIBS PKM SEP SQUIBS
270°	PES START INHIBITS
DESPUN	OMNI DEPLOY SQUIBS DESPIN RDU RELAYS

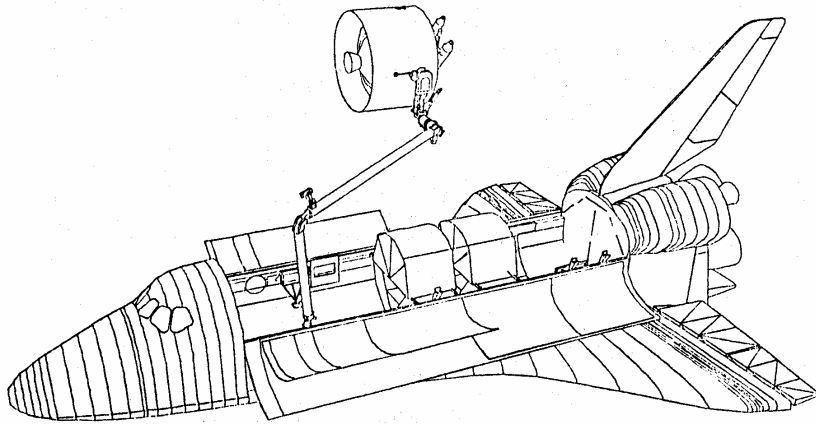

A EV1 install capture bar and stabilize Syncom.
RMS and EV1 present pivot trunnion to EV2.

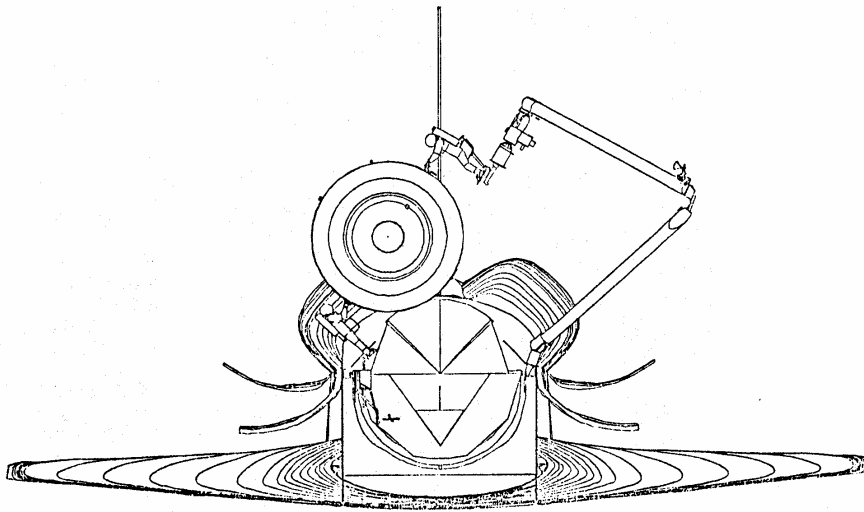

B EV2 stow separation lever and install handling bar.
EV1 install grapple bar and egress MFR.

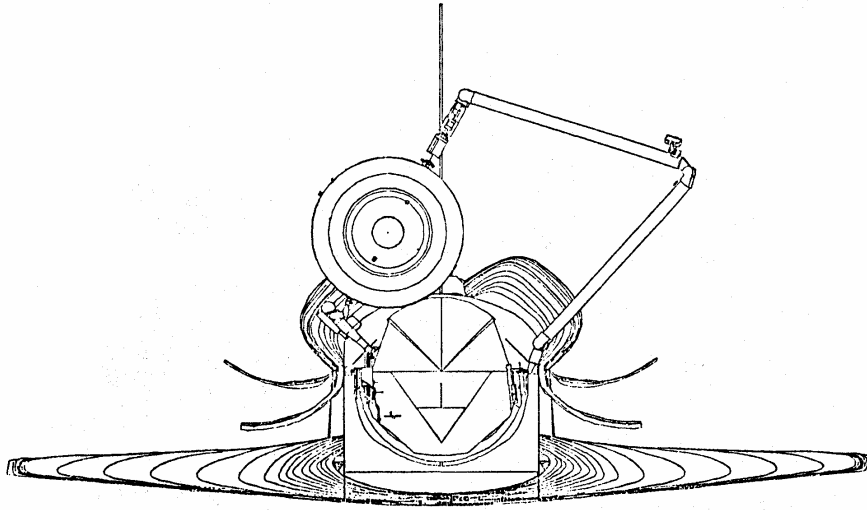

C RMS grapple.
EV1 tethered in Payload Bay.

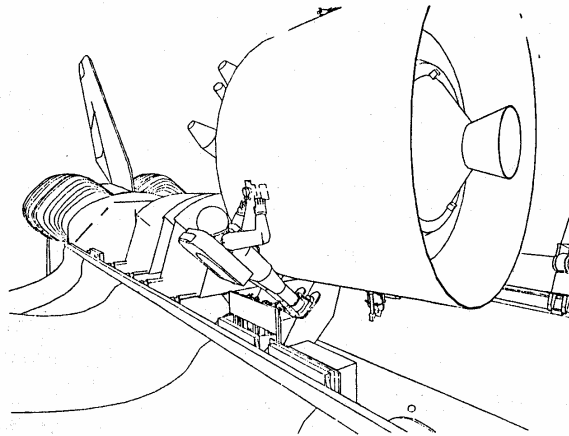

D EV2 at keel to install shorting plugs.

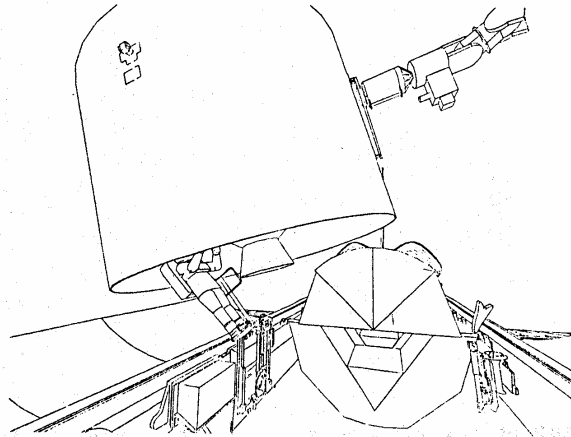

- E** EV2 at nozzle to install safing pins.
 EV2 at Syncom 135-degree point to remove access cover.

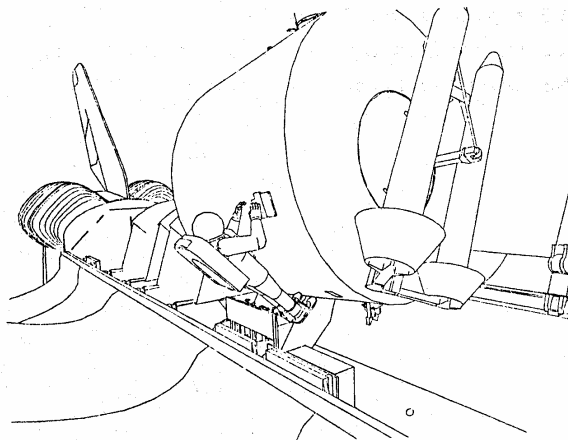

- F** EV2 at Syncom 90-degree point to remove test access cover.
 EV2 mates 4 connectors (for SBU).
 EV2 install replacement cover.
 EV2 at 135-degree point to route cable from 90-degree point.
 EV2 mates 1 connector (also for SBU).
 EV2 mounts SBU.

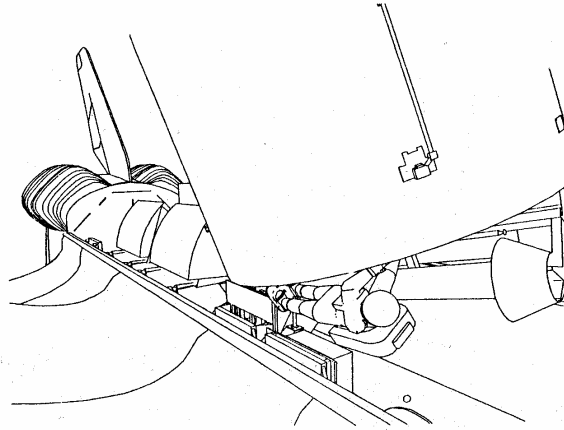

- G** EV2 at top of Syncom to remove despun test access cover.
 EV2 mates RPU.
 EV2 enables RDU relays.
 EV2 deploys omni antenna.
 EV2 caps connectors.
 EV2 installs new cover.
 EV2 at nozzle removes safing pins.
 EV2 replaces nozzle cover.
 EV2 stabilizes Syncom with handling bar.
 RMS releases Syncom, EV1 moves to MFR.

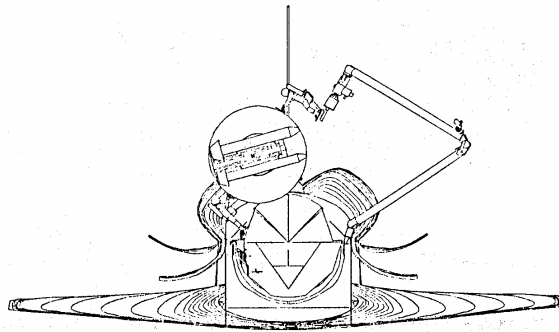

- H** EV1 installs spin-up bar.

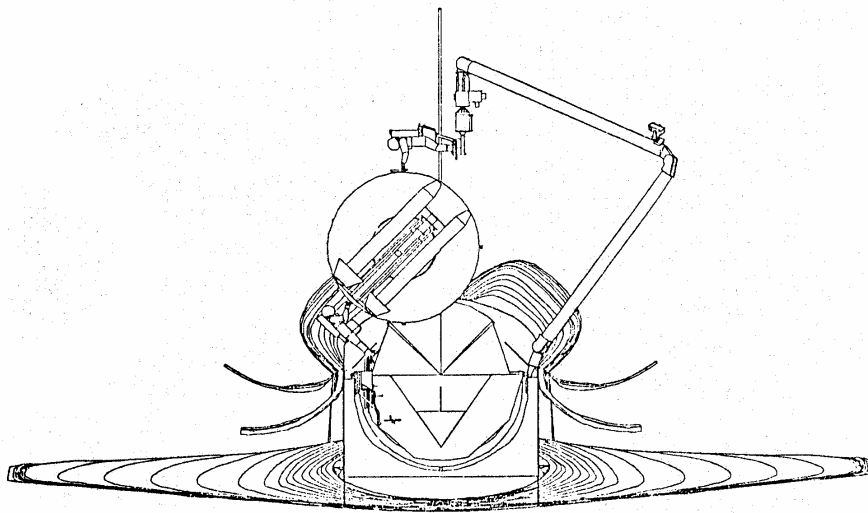

**EV2 starts SBU timers.
Maneuver Syncom and Discovery to deploy attitude.
Spin-up operations (desired rate = 2 rpm).**

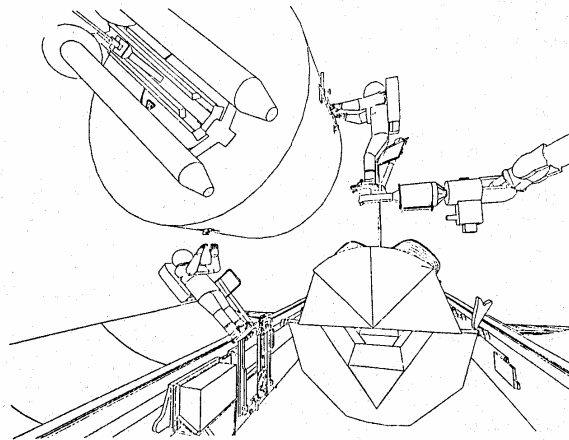

J Deploy Syncom

STS-51I CREWMEMBERS



S85-36062 – The official portrait of the STS-51I crewmembers, taken in the airlock of the crew compartment trainer includes, front row, astronauts Joe H. Engle (left), crew commander; and Richard D. Covey (right), pilot. Back row (l.-r.) includes James D. van Hoften, John M. (Mike) Lounge and William F. Fisher -- all mission specialists.

No copyright is asserted for this photograph. If a recognizable person appears in the photo, use for commercial purposes may infringe a right of privacy or publicity. It may not be used to state or imply the endorsement by NASA or by any NASA employee of a commercial product, process or service, or used in any other manner that might mislead. Accordingly, it is requested that if this photograph is used in advertising and other commercial promotion, layout and copy be submitted to NASA prior to release.

PHOTO CREDIT: NASA or National Aeronautics and Space Administration.

BIOGRAPHICAL DATA

JOE H. ENGLE, Colonel, USAF, is mission commander. Born Aug. 26, 1932, in Dickinson County, Kans., he became a NASA astronaut in 1966. Engle was back-up lunar module pilot for Apollo 14; commanded the second orbital test flight of Space Shuttle Columbia; served as deputy associate administrator for Manned Space Flight at NASA Headquarters in 1982, returning to flight status at JSC in 1983.

He received a bachelor of science degree in aeronautical engineering from the University of Kansas.

Engle was a test pilot in the X-15 research program at Edwards Air Force Base from 1963 until his assignment as NASA astronaut in 1966; served with 474th Fighter Day Squadron and 390th Tactical Fighter Squadron at George Air Force Base, Calif.; has flown more than 135 different types of aircraft (25 different fighters) and logged more than 10,800 hours -- 7,300 in jets.

RICHARD O. COVEY, Lieutenant Colonel, USAF, is the 51-I pilot. Born Aug., 1, 1946, in Fayetteville, Ark., he was selected as a NASA astronaut in 1978. Covey was T-38 chase pilot for the second and third Shuttle flights; and was a member of the Mission Control team for STS-5 and 6 as spacecraft communicator (CAPCOM).

Covey received a bachelor of science in engineering sciences from the U.S. Air Force Academy in 1968 and a master of science in aeronautics and astronautics from Purdue University.

He was an operational fighter pilot from 1970 to 1974; flew 339 combat missions during two tours in Southeast Asia; was director and pilot for electronic warfare testing of the F-15 "Eagle"; and has flown more than 3,000 hours in over 20 types of aircraft.

JAMES D. A. van HOF TEN, Ph.D., is a mission specialist. Born June 11, 1944, in Fresno, Calif., he became a NASA astronaut in 1978. van Hoft en was mission specialist on STS 41-C during which crew deployed the Long Duration Exposure Facility, retrieved and repaired the ailing Solar Maximum Satellite and flight tested the manned maneuvering units in two extravehicular activities; and has logged 168 hours in space, including ten hours of EVA flight time.

Van Hoft en received a bachelor of science degree in civil engineering from the University of California, Berkeley; and a master of science and doctor of philosophy in hydraulic engineering from Colorado State University.

Van Hoft en was a U.S. Navy pilot from 1969 to 1974, assigned to carrier USS Ranger and participated in two cruises to Southeast Asia where he flew about 60 combat missions.

He resumed academic studies in 1974 and completed a dissertation on the interaction of waves and turbulent channel flow for his doctorate; was assistant professor of civil engineering at the University of Houston until his selection as astronaut candidate; and taught fluid mechanics and conducted research on biomedical fluid flows in artificial internal organs and valves. He has logged 3,000 hours flying time, the majority in jets.

BIOGRAPHICAL DATA

JOHN M. LOUNGE, civilian, is a mission specialist. Born June 28, 1946, in Denver, he joined the NASA astronaut corps in 1980. Lounge, employed at Johnson Space Center since July 1978, was lead engineer for integration of spin-stabilized upper stage payloads into future Shuttle flights and served as a member of the Skylab reentry flight control team. He has served as launch support team member at KSC for the first three Shuttle missions; and has specialized in the Shuttle's computer system.

Lounge received a bachelor of science degree in physics and mathematics from the U.S. Naval Academy and a master of science degree in astrophysics from the University of Colorado.

Following graduation from the U.S. Naval Academy, Lounge completed Naval flight officer training at Pensacola, Fla., and took advanced training as radar intercept officer in the F-4J Phantom; completed a 9-month Southeast Asia cruise aboard the USS Enterprise, participating in 99 combat missions; transferred to the Navy Space Project office in Washington, D.C., for 2-year tour as staff project officer; and resigned his U.S. Navy commission in 1978.

WILLIAM P. FISHER, MD, is a mission specialist. Born April 1, 1946, in Dallas, he was selected as a NASA astronaut in 1980. Fisher's assignments include B-57 scientific equipment operator for high altitude research; extravehicular mobility unit and extravehicular activity procedures; hardware and software development for PAM-D; CAPCOM for STS-8 and STS-9; and concurrently served as deputy director of NASA government and contractor-furnished equipment.

Fisher received a bachelor of arts from Stanford University in 1968, a doctorate in medicine from the University of Florida and a master of science in engineering from the University of Houston.

After medical school, Fisher completed surgical residency at the University of California, Los Angeles Harbor General Hospital in Torrance, Calif., he specialized in emergency medicine from 1977 to 1980; and is currently practicing emergency medicine at Clear Lake Hospital, Houston. He has logged over 1,100 hours in prop, rotary-wing and jet aircraft.

SHUTTLE FLIGHTS AS OF AUGUST 1985

19 TOTAL FLIGHTS OF THE SHUTTLE



	STS-51F 07/29/85 - 08/06/85	
	STS-51B 04/29/85 - 05/06/85	
STS-9 11/28/83 - 12/08/83	STS-41G 10/05/84 - 10/13/84	
STS-5 11/11/82 - 11/16/82	STS-41C 04/06/84 - 04/13/84	STS-51G 06/17/85 - 06/24/85
STS-4 06/27/82 - 07/04/82	STS-41B 02/03/84 - 02/11/84	STS-51D 04/12/85 - 04/19/85
STS-3 03/22/82 - 03/30/82	STS-8 08/30/83 - 09/05/83	STS-51C 01/24/85 - 01/27/85
STS-2 11/12/81 - 11/14/81	STS-7 06/18/83 - 06/24/83	STS-51A 11/08/84 - 11/16/84
STS-1 04/12/81 - 04/14/81	STS-6 04/04/83 - 04/09/83	STS-41D 08/30/84 - 09/05/84

OV-102
Columbia
(6 flights)

OV-099
Challenger
(8 flights)

OV-103
Discovery
(5 flights)